



# FAST CMOS 16-BIT BIDIRECTIONAL 3.3V TO 5V TRANSLATOR

## IDT74FCT164245T

### FEATURES:

- 0.5 MICRON CMOS Technology
- Bidirectional interface between 3.3V and 5V buses
- Control inputs can be driven from either 3.3V or 5V circuits
- ESD > 2000V per MIL-STD-883, Method 3015; > 200V using machine model (C = 200pF, R = 0)
- $V_{CC1} = 5V \pm 10\%$ ,  $V_{CC2} = 2.7V$  to  $3.6V$
- High drive outputs (-32mA IOH, 64mA IOL) on 5V port
- Power off disable on both ports permits "live insertion"
- Typical VOLP (Output Ground Bounce) < 0.9V at  $V_{CC1} = 5V$ ,  $V_{CC2} = 3.3V$ ,  $T_A = 25^\circ C$
- Available in SSOP and TSSOP packages

### DESCRIPTION:

The FCT164245T 16-bit 3.3V-to-5V translator is built using advanced dual metal CMOS technology. This high-speed, low-power transceiver is designed to interface between a 3.3V bus and a 5V bus in a mixed 3.3V/5V supply environment. This enables system designers to interface TTL compatible 3.3V components with 5V components. The direction and output enable controls operate these devices as either two independent 8-bit transceivers or one 16-bit transceiver. The A port interfaces with the 3.3V bus; the B port interfaces with the 5V bus. The direction control (xDIR) pin controls the direction of data flow. The output enable pin (x $\overline{OE}$ ) overrides the direction control and disables both ports. These control signals can be driven from either 3.3V or 5V devices.

The FCT164245T is ideally suited for driving high-capacitance loads and low-impedance backplanes. The output buffers are designed with power off disable capability to allow "hot insertion" of boards when used as backplane drivers. They also allow interface between a mixed supply system and external 5 volt peripherals.

### FUNCTIONAL BLOCK DIAGRAM

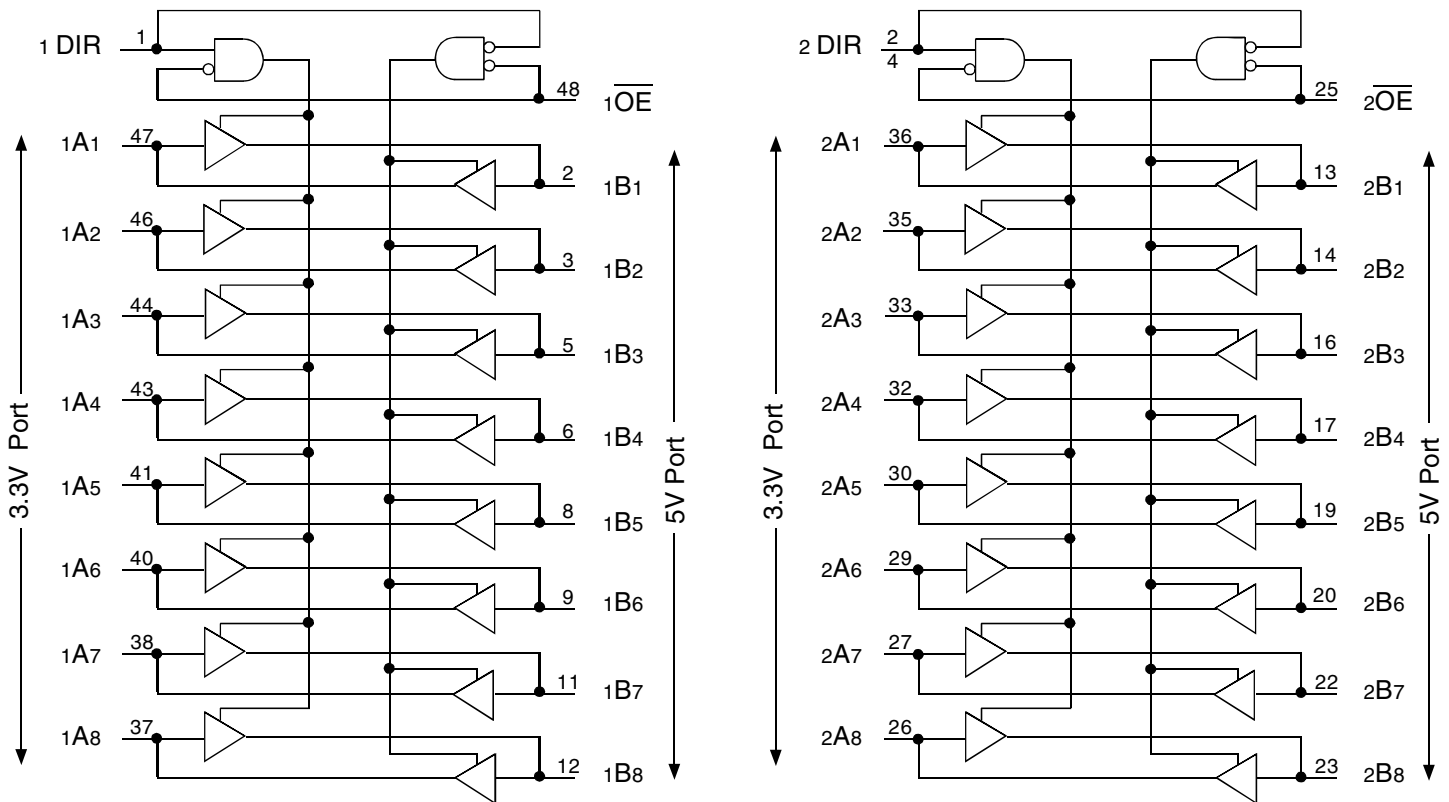

The IDT logo is a registered trademark of Integrated Device Technology, Inc.

## PIN CONFIGURATION

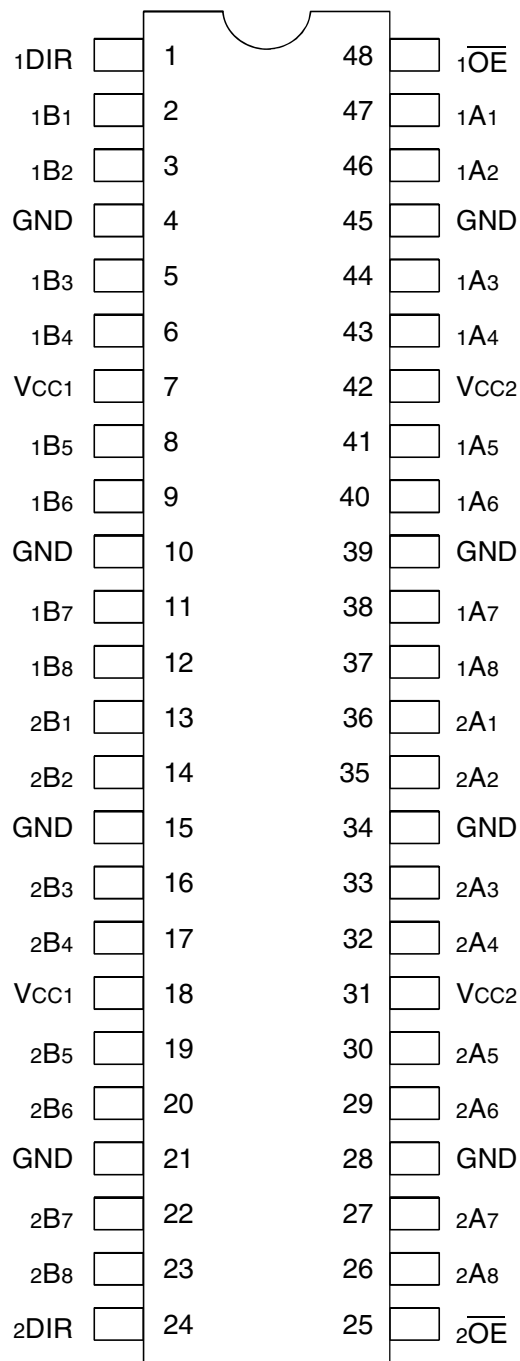

SSOP/ TSSOP  
TOP VIEW

## POWER SUPPLY SEQUENCING

In the 74FCT164245T, the condition of  $V_{CC1} \geq (V_{CC2} - 0.5V)$  must be maintained at all times. For the range of  $V_{CC1} = (V_{CC2} - 0.5V)$  to  $V_{CC1} = (V_{CC2} + 0.9V)$ , both the A and B ports will remain in a High-Impedance state.

## ABSOLUTE MAXIMUM RATINGS<sup>(1)</sup>

Symbol	Description	Max	Unit
$V_{TERM}^{(2)}$	Terminal Voltage with Respect to GND	-0.5 to +7	V
$V_{TERM}^{(3)}$	Terminal Voltage with Respect to GND	-0.5 to $V_{CC1}+0.5$	V
$T_A$	Operating Temperature	-40 to +85	°C
$T_{BIAS}$	Temperature Under Bias	-55 to +125	°C
$T_{STG}$	Storage Temperature	-55 to +125	°C
$P_T$	Power Dissipation	1	W
$I_{OUT}$	DC Output Current	-60 to +120	mA

### NOTES:

- Stresses greater than those listed under ABSOLUTE MAXIMUM RATINGS may cause permanent damage to the device. This is a stress rating only and functional operation of the device at these or any other conditions above those indicated in the operational sections of this specification is not implied. Exposure to absolute maximum rating conditions for extended periods may affect reliability.
- All devices except  $V_{CC2}$ .
- Power supply terminal  $V_{CC2}$ .

## CAPACITANCE ( $T_A = +25^\circ\text{C}$ , $F = 1.0\text{MHz}$ )

Symbol	Parameter <sup>(1)</sup>	Conditions	Typ.	Max.	Unit
$C_{IN}$	Input Capacitance	$V_{IN} = 0V$	3.5	6	pF
$C_{I/O}$	I/O Capacitance	$V_{OUT} = 0V$	3.5	8	pF

### NOTE:

- This parameter is measured at characterization but not tested.

## PIN DESCRIPTION

Pin Names	Description
$\overline{xOE}$	Output Enable Input (Active LOW)
xDIR	Direction Control Input
xAx	Side A Inputs or 3-State Outputs (3.3V Port)
xBx	Side B Inputs or 3-State Outputs (5V Port)

## FUNCTION TABLE<sup>(1)</sup>

Inputs		Outputs
$\overline{xOE}$	xDIR	
L	L	Bus B Data to Bus A
L	H	Bus A Data to Bus B
H	X	High Z State

### NOTE:

- H = HIGH Voltage Level  
L = LOW Voltage Level  
X = Don't Care  
Z = High-Impedance

## DC ELECTRICAL CHARACTERISTICS OVER OPERATING RANGE (A PORT, 3.3V)

Following Conditions Apply Unless Otherwise Specified:

V<sub>CC1</sub> = 5V ±10%, V<sub>CC2</sub> = 2.7V to 3.6V, Industrial: T<sub>A</sub> = -40°C to +85°C

Symbol	Parameter	Test Conditions <sup>(1)</sup>	Min.	Typ. <sup>(2)</sup>	Max.	Unit
V <sub>IH</sub>	Input HIGH Level (Input and I/O pins)	Guaranteed Logic HIGH Level	2	—	5.5	V
V <sub>IL</sub>	Input LOW Level (Input and I/O pins)	Guaranteed Logic LOW Level	-0.5	—	0.8	V
I <sub>IH</sub>	Input HIGH Current (Input pins)	V <sub>CC1</sub> = Max. V <sub>I</sub> = 5.5V	—	—	±5	μA
	Input HIGH Current (I/O pins)	V <sub>CC2</sub> = Max. V <sub>I</sub> = V <sub>CC2</sub>	—	—	±15	
I <sub>IL</sub>	Input LOW Current (Input pins)	V <sub>I</sub> = GND	—	—	±5	
	Input LOW Current (I/O pins)	V <sub>I</sub> = GND	—	—	±15	
V <sub>IK</sub>	Clamp Diode Voltage	V <sub>CC2</sub> = Min., I <sub>IN</sub> = -18mA	—	-0.7	-1.2	V
V <sub>OH</sub>	Output HIGH Voltage	V <sub>CC1</sub> = V <sub>CC2</sub> = Min. V <sub>IN</sub> = V <sub>IH</sub> or V <sub>IL</sub> I <sub>OH</sub> = -0.1mA	V <sub>CC2</sub> -0.2	—	—	V
		V <sub>CC2</sub> = 3V V <sub>IN</sub> = V <sub>IH</sub> or V <sub>IL</sub> I <sub>OH</sub> = -8mA	2.4	3	—	
V <sub>OL</sub>	Output LOW Voltage	V <sub>CC1</sub> = Min. V <sub>CC2</sub> = Min. V <sub>IN</sub> = V <sub>IH</sub> or V <sub>IL</sub> I <sub>OL</sub> = 0.1mA	—	—	0.2	V
		I <sub>OL</sub> = 16mA	—	0.2	0.4	
		I <sub>OL</sub> = 24mA	—	0.3	0.55	
		V <sub>CC</sub> = 3V V <sub>IN</sub> = V <sub>IH</sub> or V <sub>IL</sub> I <sub>OL</sub> = 24mA	—	0.3	0.5	
I <sub>OFF</sub>	Input/Output Power Off Leakage	V <sub>CC1</sub> = 0V, V <sub>CC2</sub> = 0V, V <sub>IN</sub> or V <sub>O</sub> ≤ 4.5V	—	—	±100	μA
I <sub>OS</sub>	Short Circuit Current <sup>(4)</sup>	V <sub>CC1</sub> = Max., V <sub>CC2</sub> = Max., V <sub>O</sub> = GND <sup>(3)</sup>	-70	-105	-150	mA
I <sub>O</sub>	Output Drive Current	V <sub>CC1</sub> = Max., V <sub>CC2</sub> = Max., V <sub>O</sub> = 1.5V <sup>(3)</sup>	-40	-60	-90	mA
V <sub>H</sub>	Input Hysteresis	—	—	150	—	mV
I <sub>CC2</sub>	Quiescent Power Supply Current	V <sub>CC1</sub> = Max.	—	0.35	2	mA
I <sub>CC2H</sub>		V <sub>CC2</sub> = Max.				
I <sub>CC2Z</sub>		V <sub>IN</sub> = GND or V <sub>CC2</sub>				

### NOTES:

1. For conditions shown as Min. or Max., use appropriate value specified under Electrical Characteristics for the applicable device type.
2. Typical values are at V<sub>CC1</sub> = 5V, V<sub>CC2</sub> = 3.3V, +25°C ambient.
3. Not more than one output should be shorted at one time. Duration of the test should not exceed one second.
4. This parameter is guaranteed but not tested.

## DC ELECTRICAL CHARACTERISTICS OVER OPERATING RANGE (B PORT, 5V)

Following Conditions Apply Unless Otherwise Specified:

$V_{CC1} = 5V \pm 10\%$ ,  $V_{CC2} = 2.7V$  to  $3.6V$ , Industrial:  $T_A = -40^\circ C$  to  $+85^\circ C$

Symbol	Parameter	Test Conditions <sup>(1)</sup>	Min.	Typ. <sup>(2)</sup>	Max.	Unit
$V_{IH}$	Input HIGH Level (Input and I/O pins)	Guaranteed Logic HIGH Level	2	—	5.5	V
$V_{IL}$	Input LOW Level (Input and I/O pins)	Guaranteed Logic LOW Level	-0.5	—	0.8	V
$I_{IH}$	Input HIGH Current (Input pins)	$V_{CC1} = \text{Max.}$ $V_i = V_{CC1}$	—	—	$\pm 5$	$\mu A$
	Input HIGH Current (I/O pins)	$V_{CC2} = \text{Max.}$	—	—	$\pm 15$	
$I_{IL}$	Input LOW Current (Input pins)	$V_i = \text{GND}$	—	—	$\pm 5$	
	Input LOW Current (I/O pins)		—	—	$\pm 15$	
$V_{IK}$	Clamp Diode Voltage	$V_{CC1} = \text{Min.}, I_{IN} = -18\text{mA}$	—	-0.7	-1.2	V
$V_{OH}$	Output HIGH Voltage	$V_{CC1} = \text{Min.}$ $I_{OH} = -3\text{mA}$	2.5	3.5	—	V
		$V_{CC2} = \text{Min.}$ $I_{OH} = -15\text{mA}$	2.4	3.5	—	
		$V_{IN} = V_{IH}$ or $V_{IL}$ $I_{OH} = -32\text{mA}^{(5)}$	2	3	—	
$V_{OL}$	Output LOW Voltage	$V_{CC1} = \text{Min.}$ $V_{CC2} = \text{Min.}$ $V_{IN} = V_{IH}$ or $V_{IL}$ $I_{OL} = 64\text{mA}$	—	0.2	0.55	V
$I_{OFF}$	Input/Output Power Off Leakage	$V_{CC1} = 0V, V_{CC2} = 0V, V_{IN}$ or $V_o \leq 4.5V$	—	—	$\pm 100$	$\mu A$
$I_{OS}$	Short Circuit Current <sup>(4)</sup>	$V_{CC1} = \text{Max.}, V_{CC2} = \text{Max.}, V_o = \text{GND}^{(3)}$	-80	-140	-225	mA
$I_o$	Output Drive Current	$V_{CC1} = \text{Max.}, V_{CC2} = \text{Max.}, V_o = 2.5V^{(3)}$	-50	-75	-180	mA
$V_H$	Input Hysteresis	—	—	150	—	mV
$I_{CC2}$ $I_{CC2H}$ $I_{CC2Z}$	Quiescent Power Supply Current	$V_{CC1} = \text{Max.}$ $V_{CC2} = \text{Max.}$ $V_{IN} = \text{GND}$ or $V_{CC2}$	—	0.08	1.5	mA

### NOTES:

1. For conditions shown as Min. or Max., use appropriate value specified under Electrical Characteristics for the applicable device type.
2. Typical values are at  $V_{CC1} = 5V, V_{CC2} = 3.3V, +25^\circ C$  ambient.
3. Not more than one output should be shorted at one time. Duration of the test should not exceed one second.
4. This parameter is guaranteed but not tested.
5. Duration of the condition cannot exceed one second.

## POWER SUPPLY CHARACTERISTICS

Symbol	Parameter	Test Conditions <sup>(1)</sup>		Min.	Typ. <sup>(2)</sup>	Max.	Unit
$\Delta I_{CC}$	Quiescent Power Supply Current TTL Inputs HIGH	$V_{CC1} = \text{Max.}, V_{CC2} = \text{Max.}$ $V_{IN} = V_{CC2} - 0.6V^{(3)}$		—	12	30	$\mu A$
$I_{CCD}$	Dynamic Power Supply Current <sup>(4)</sup>	$V_{CC1} = \text{Max.}, V_{CC2} = \text{Max.}$ Outputs Open $\overline{xOE} = xDIR = GND$ One Input Toggling 50% Duty Cycle	$V_{IN} = V_{CC2}$ $V_{IN} = GND$	—	75	120	$\mu A /$ MHz
$I_C$	Total Power Supply Current <sup>(6)</sup>	$V_{CC1} = \text{Max.}, V_{CC2} = \text{Max.}$ Outputs Open $f_i = 10\text{MHz}$ 50% Duty Cycle $\overline{xOE} = xDIR = GND$ One Bit Toggling	$V_{IN} = V_{CC2} - 0.6V$ $V_{IN} = GND$	—	1.2	4.7	mA
		$V_{CC1} = \text{Max.}, V_{CC2} = \text{Max.}$ Outputs Open $f_i = 2.5\text{MHz}$ 50% Duty Cycle $\overline{xOE} = xDIR = GND$ Sixteen Bits Toggling	$V_{IN} = V_{CC2} - 0.6V$ $V_{IN} = GND$	—	3.5	8.5 <sup>(5)</sup>	

### NOTES:

- For conditions shown as Min. or Max., use appropriate value specified under Electrical Characteristics for the applicable device type.
- Typical values are at  $V_{CC1} = 5V, V_{CC2} = 3.3V, +25^\circ C$  ambient.
- Per TTL driven input. All other inputs at Vcc or GND.
- This parameter is not directly testable, but is derived for use in Total Power Supply Calculations.
- Values for these conditions are examples of the  $I_{CC}$  formula. These limits are guaranteed but not tested.
- $I_C = I_{QUIESCENT} + I_{INPUTS} + I_{DYNAMIC}$   
 $I_C = I_{CC1} + I_{CC2} + \Delta I_{CC} D_H N_T + I_{CCD} (f_{CP} N_{CP} / 2 + f_i N_i)$   
 $I_{CC1} = \text{Quiescent Current } (I_{CC1L}, I_{CC1H} \text{ and } I_{CC1Z})$   
 $I_{CC2} = \text{Quiescent Current } (I_{CC2L}, I_{CC2H} \text{ and } I_{CC2Z})$   
 $\Delta I_{CC} = \text{Power Supply Current for a TTL High Input}$   
 $D_H = \text{Duty Cycle for TTL Inputs High}$   
 $N_T = \text{Number of TTL Inputs at } D_H$   
 $I_{CCD} = \text{Dynamic Current caused by an Input Transition Pair (HLH or LHL)}$   
 $f_{CP} = \text{Clock Frequency for Register Devices (Zero for Non-Register Devices)}$   
 $N_{CP} = \text{Number of Clock Inputs at } f_{CP}$   
 $f_i = \text{Input Frequency}$   
 $N_i = \text{Number of Inputs at } f_i$

SWITCHING CHARACTERISTICS OVER OPERATING RANGE<sup>(1)</sup>

Symbol	Parameter	Condition <sup>(1)</sup>	Min. <sup>(2)</sup>	Max.	Unit
t <sub>PLH</sub> t <sub>PHL</sub>	Propagation Delay A to B	CL = 50pF RL = 500Ω	1.5	5	ns
t <sub>PLH</sub> t <sub>PHL</sub>	Propagation Delay B to A		1.5	5	ns
t <sub>PZH</sub> t <sub>PZL</sub>	Output Enable Time x $\overline{OE}$ to B		1.5	6.5	ns
t <sub>PHZ</sub> t <sub>PLZ</sub>	Output Disable Time x $\overline{OE}$ to B		1.5	6	ns
t <sub>PZH</sub> t <sub>PZL</sub>	Output Enable Time x $\overline{OE}$ to A		1.5	6.5	ns
t <sub>PHZ</sub> t <sub>PLZ</sub>	Output Disable Time x $\overline{OE}$ to A		1.5	6	ns
t <sub>PZH</sub> t <sub>PZL</sub>	Output Enable Time xDIR to B <sup>(3)</sup>		1.5	6.5	ns
t <sub>PHZ</sub> t <sub>PLZ</sub>	Output Disable Time xDIR to B <sup>(3)</sup>		1.5	6	ns
t <sub>PZH</sub> t <sub>PZL</sub>	Output Enable Time xDIR to A <sup>(3)</sup>		1.5	6.5	ns
t <sub>PHZ</sub> t <sub>PLZ</sub>	Output Disable Time xDIR to A <sup>(3)</sup>		1.5	6	ns

NOTES:

1. See test circuit and waveforms.
2. Minimum limits are guaranteed but not tested on Propagation Delays.
3. This parameter is guaranteed but not tested.

### TEST CIRCUITS AND WAVEFORMS

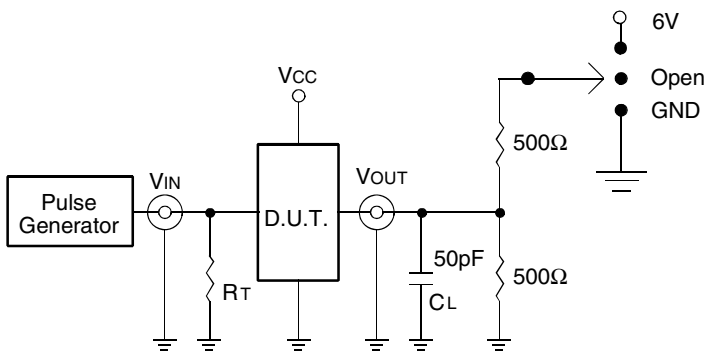

Test Circuits for All Outputs

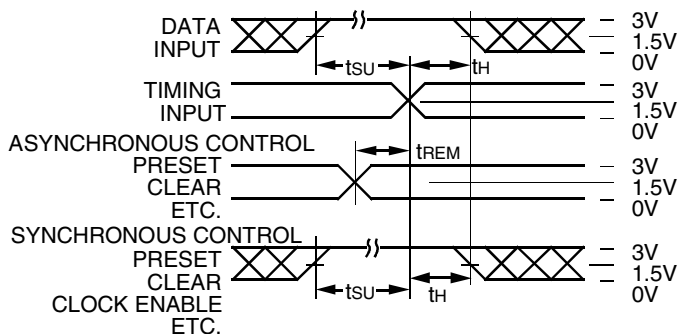

Set-up, Hold, and Release Times

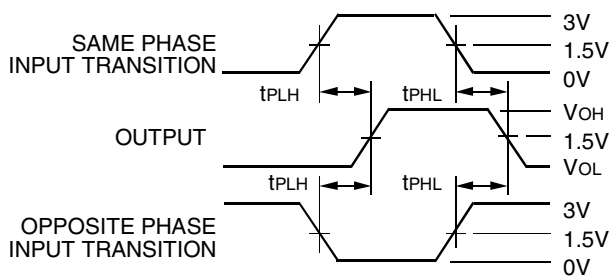

Propagation Delay

### SWITCH POSITION

Test	Switch
Open Drain Disable Low Enable Low	6V
Disable High Enable High	GND
All Other Tests	Open

**DEFINITIONS:**

CL = Load capacitance: includes jig and probe capacitance.  
RT = Termination resistance: should be equal to ZOUT of the Pulse Generator.

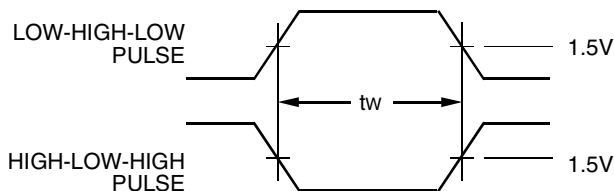

Pulse Width

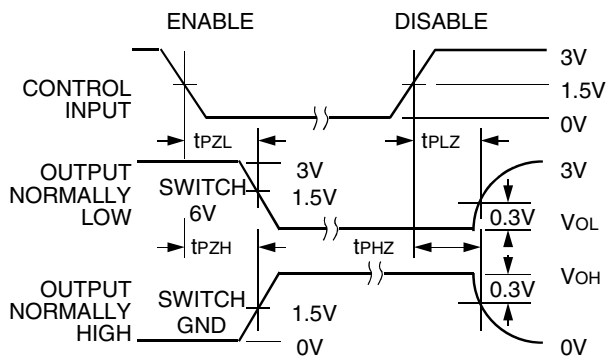

Enable and Disable Times

**NOTES:**

1. Diagram shown for input Control Enable-LOW and input Control Disable-HIGH.
2. Pulse Generator for All Pulses: Rate ≤ 1.0MHz; tr ≤ 2.5ns; tr ≤ 2.5ns.

**ORDERING INFORMATION**

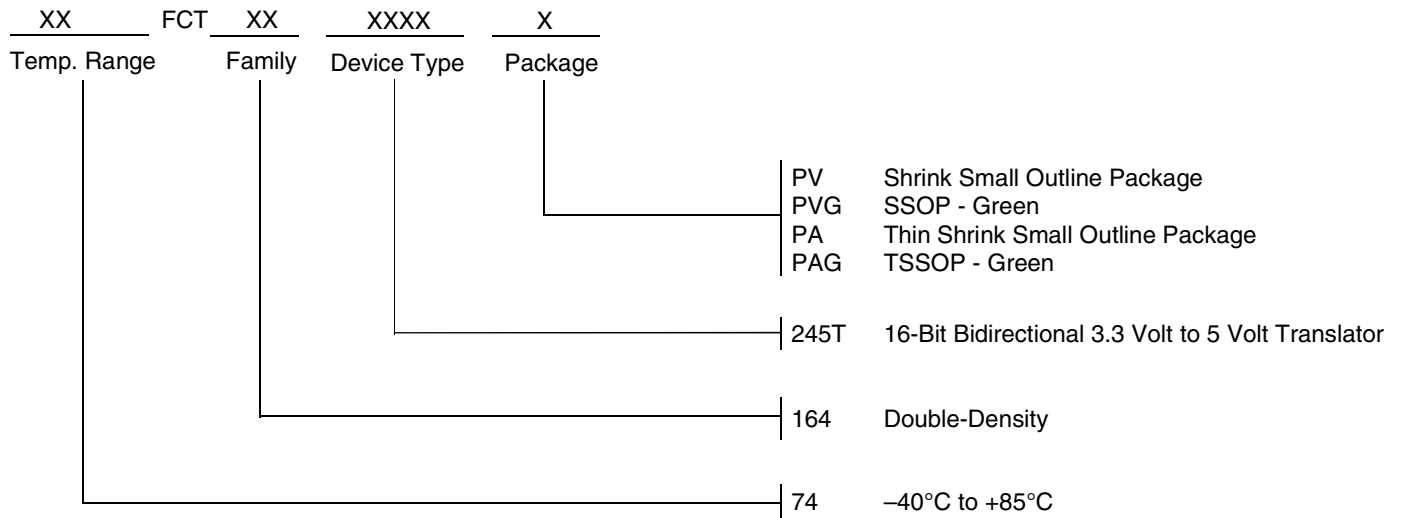

**CORPORATE HEADQUARTERS**  
 6024 Silver Creek Valley Road  
 San Jose, CA 95138

**for SALES:**  
 800-345-7015 or 408-284-8200  
 fax: 408-284-2775  
[www.idt.com](http://www.idt.com)

**for Tech Support:**  
[logichelp@idt.com](mailto:logichelp@idt.com)